

A thick black L-shaped graphic in the top right corner, consisting of a horizontal bar and a vertical bar meeting at a right angle.

***Templex inc.***

**2017**

**Products for Hosiery  
Manufacturing Equipment**

**Templex inc.**

## Products for Hosiery Manufacturing Equipment

**Templex Inc. Since 1956**

Air Valves / Vacuum Valves / Product Diverters .....	H 11
Bentley Knitting Machine Parts .....	H 11
Busi Knitting Machine Parts .....	H 9
Cleaning Gun .....	H 11
Collectors Units / Lay-out Units .....	H 12
Collection System .....	H 3
Complett Seaming Machine Parts .....	H 17
Compressed Air Fittings .....	H 12, H 16
Crawford Knitting Machine Parts .....	H 11
Detexomat Seaming Machine Parts .....	H 17
Fimatex Seaming Machine Parts .....	H 11
Hose Adapters .....	H 13
Hose Clamps .....	H 14
Hose Products, Vacuum Hose .....	H 15
Inspection Forms .....	H 11
Inline Filters .....	H 13
Inline Waste Container and Caps .....	H 13
Lonati Knitting Machine Parts .....	H 4 - H 5
Matec Knitting Machine Parts .....	H 6- H 8
Mufflers .....	H 13
Rosso Seaming Machine Parts .....	H 17
Rumi Knitting Machine Parts .....	H 9
Sangiaco Knitting Machine Parts .....	H 9
Santoni Knitting Machine Parts .....	H 9 - H 10
Seaming Accessories .....	H 18
Solis- Hemphill Knitting Machine Parts .....	H 11
Takatori Seaming Machine Parts .....	H 17
Tubing, Compressd Air/ Oil Line .....	H 14
Turn-Sew-Turn Units / Turning Tubes .....	H 19
Uniplett Knitting Machine Parts .....	H 11

Shipping:  
Templex Inc.  
3 Stanley Ave.  
Thomasville, NC 27360 USA

Mailing:  
Templex Inc.  
PO Box 5648  
High Point, NC 27262 USA

Telephone ..... 336-472-5933  
Fax ..... 336-472-5944  
Toll Free USA ..... 1-800-344-2725  
E-Mail ..... [Templexinc@aol.com](mailto:Templexinc@aol.com)  
Web ..... [www.TemplexInc.com](http://www.TemplexInc.com)

### Other Products From Templex

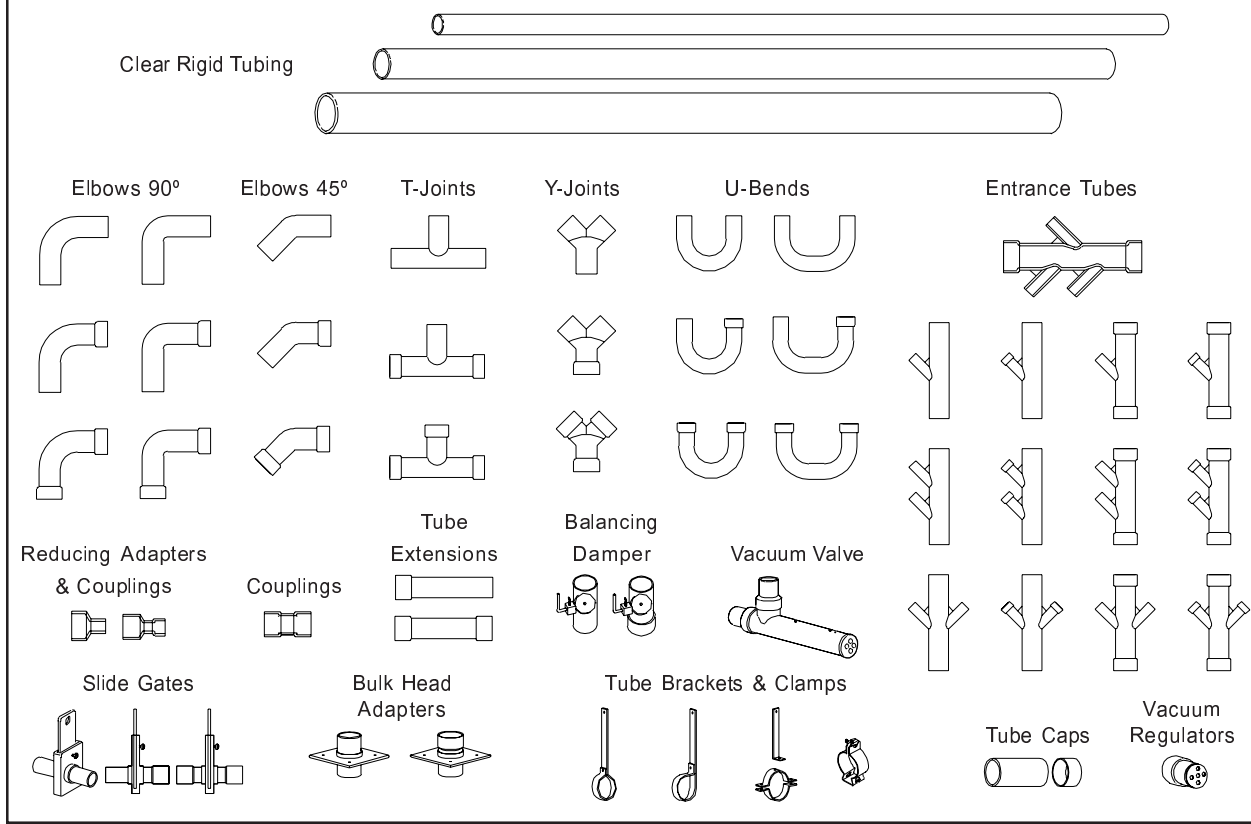

### Hosiery Collection and Transport Systems

- Eliminate Material Handling Problems
- Reduce Labor Cost
- Increase Quality
- Reduce Inventory
- Streamline and Speed the Flow of In-process Work Through the Plant
- Eliminate Greige Collection at Knitting Machines
- Allow Additional Machines in Existing Space

*Now Socks can be Transported up to 600 Ft.*

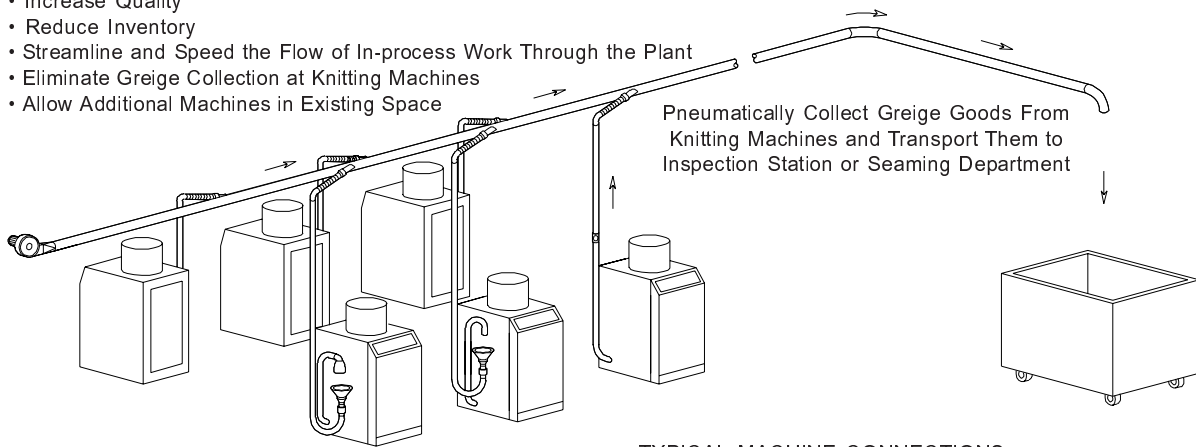

TYPICAL MACHINE CONNECTIONS

Available For All Types of Machines

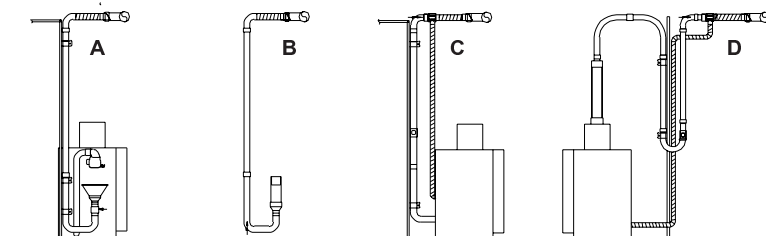

Collection System Video Tape is Available Upon Request

## Lonati 454 & 454J

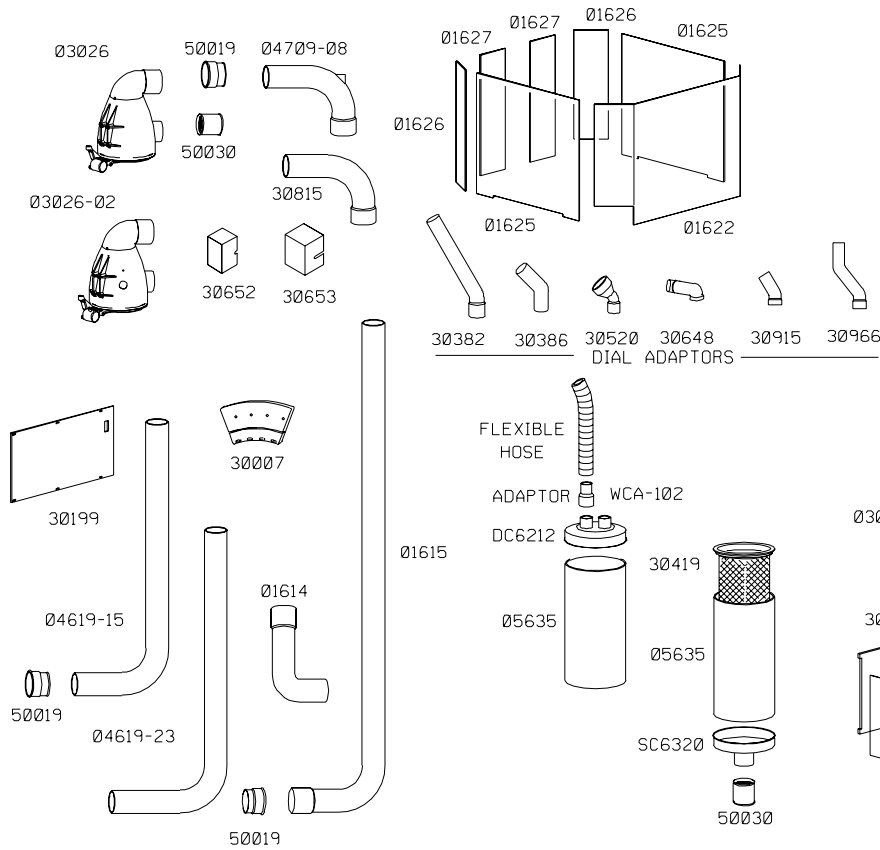

## Lonati Bravo

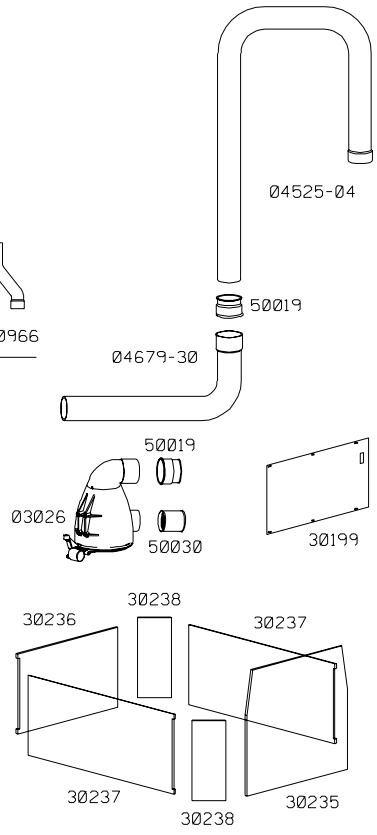

## Lonati Goal 300 Series

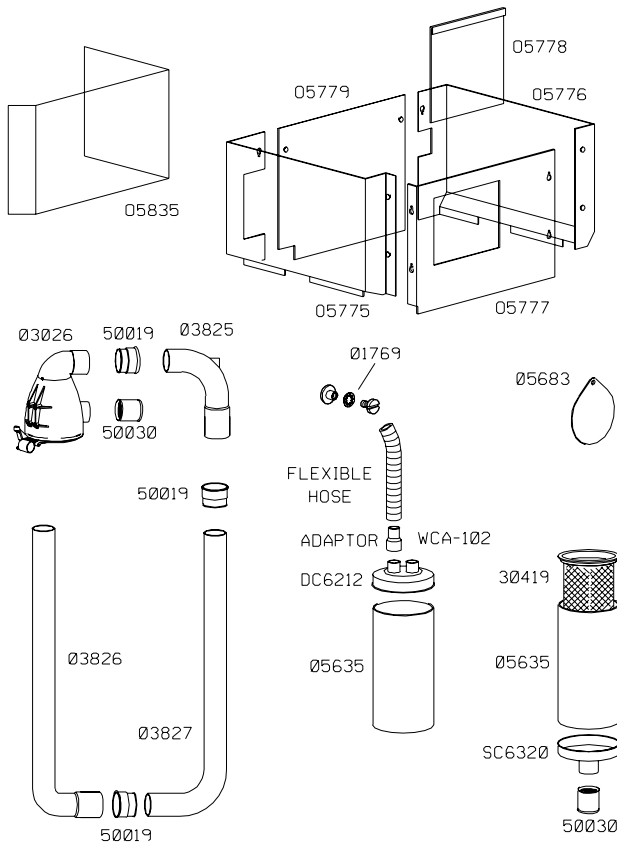

## Lonati Jr / Master / Monster

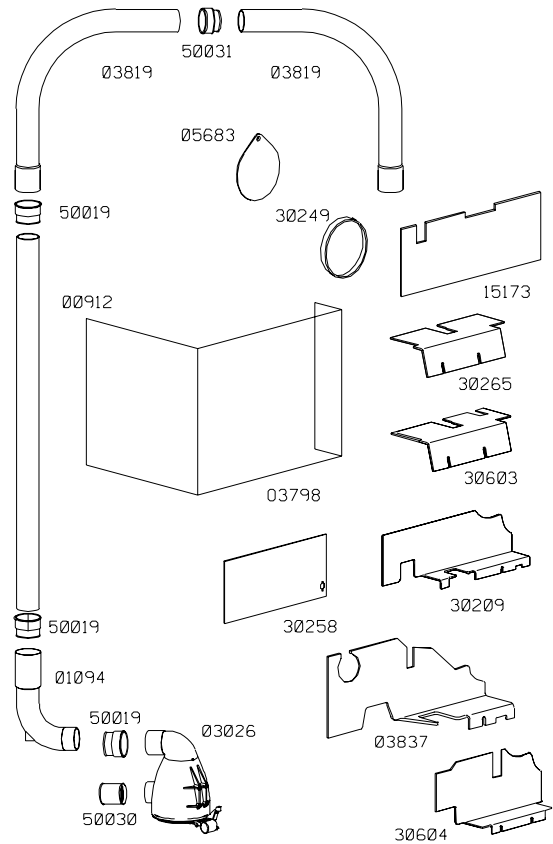



## Matec Veloce, Fantasia, HS

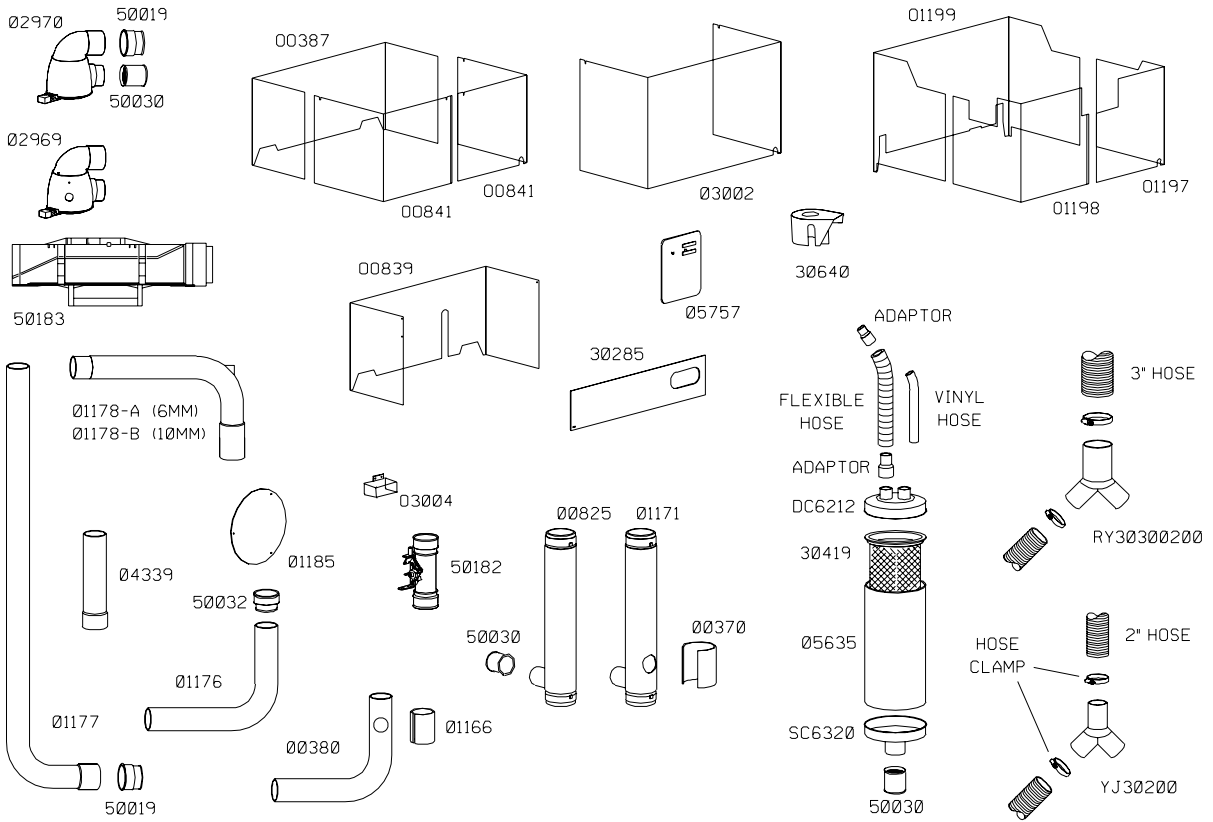

## Matec HSE / Pois DM / Fantasia E

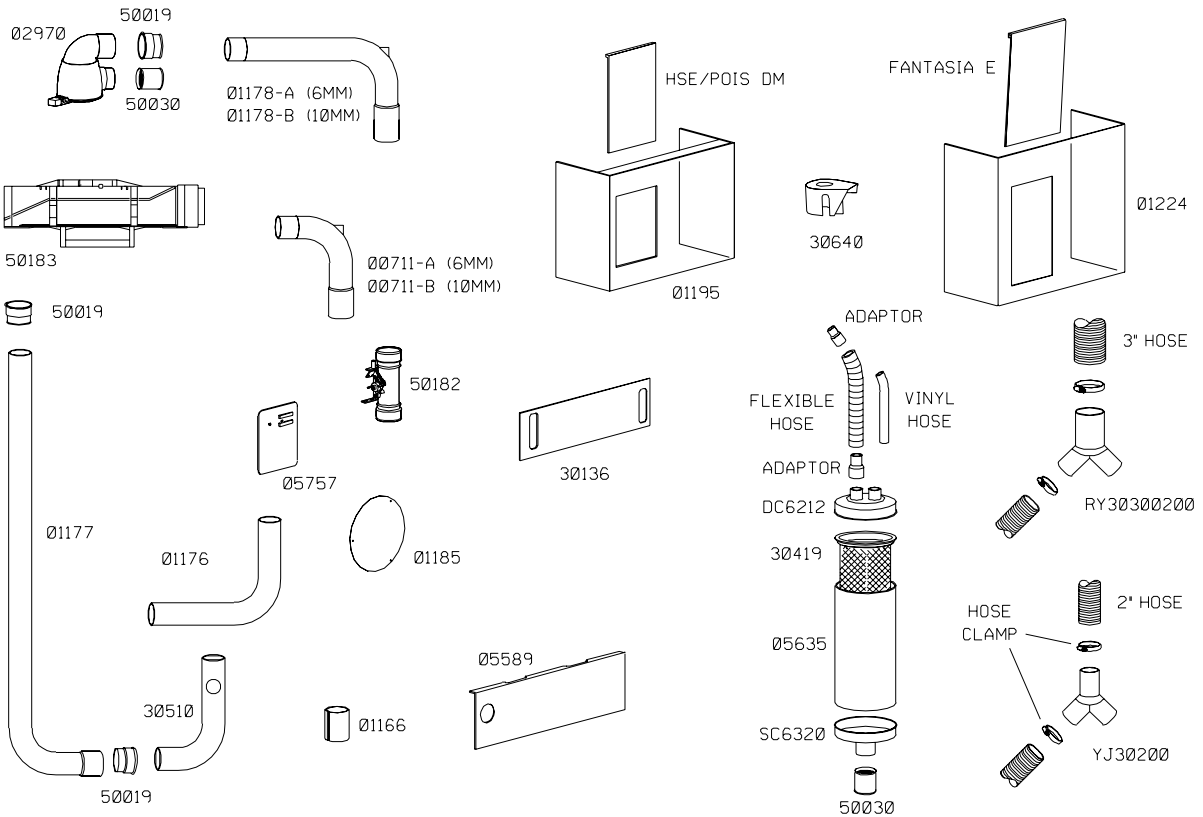

**Matec Ultra Series, Ladies**

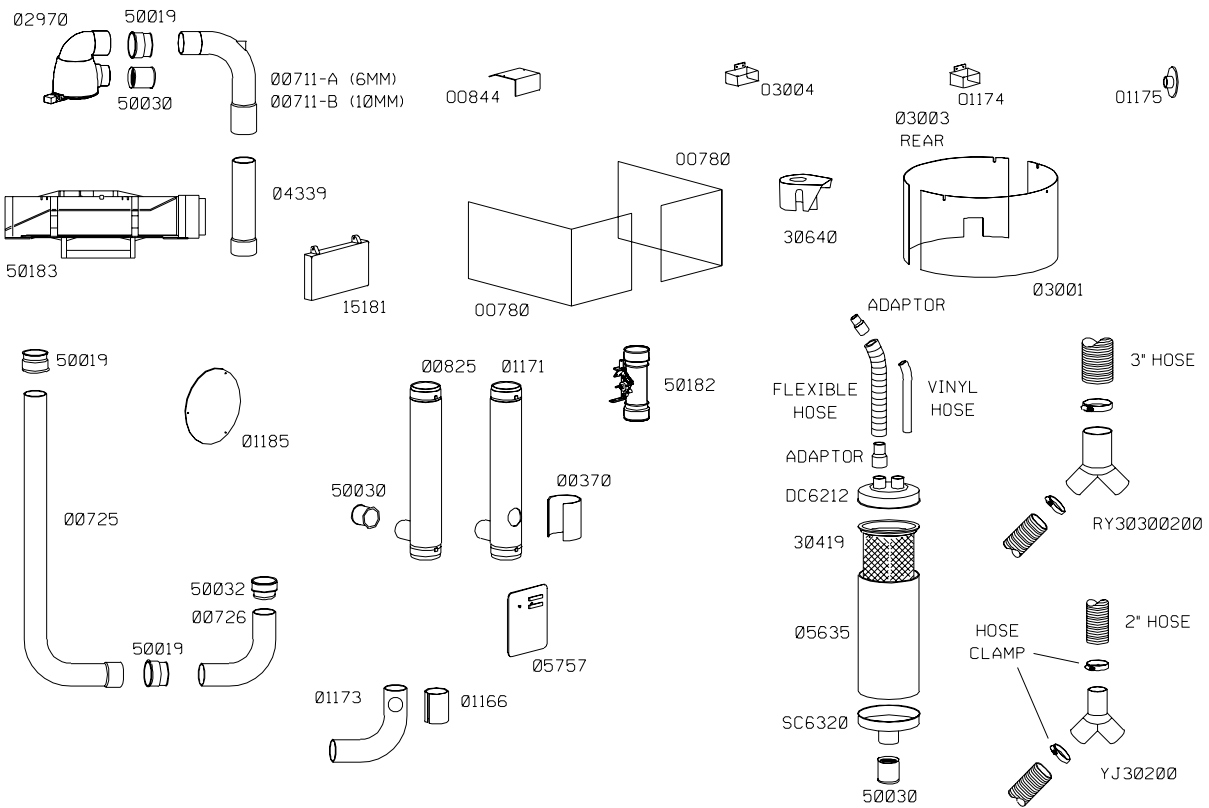

**Matec HF**

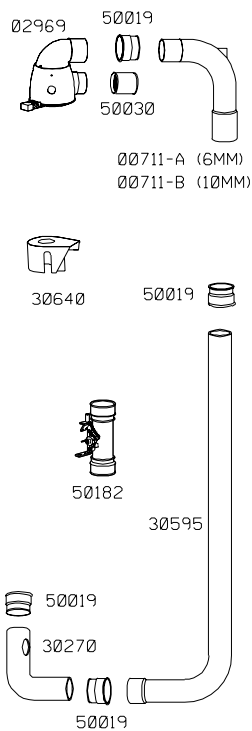

**Matec 2000 / 3000 Series**

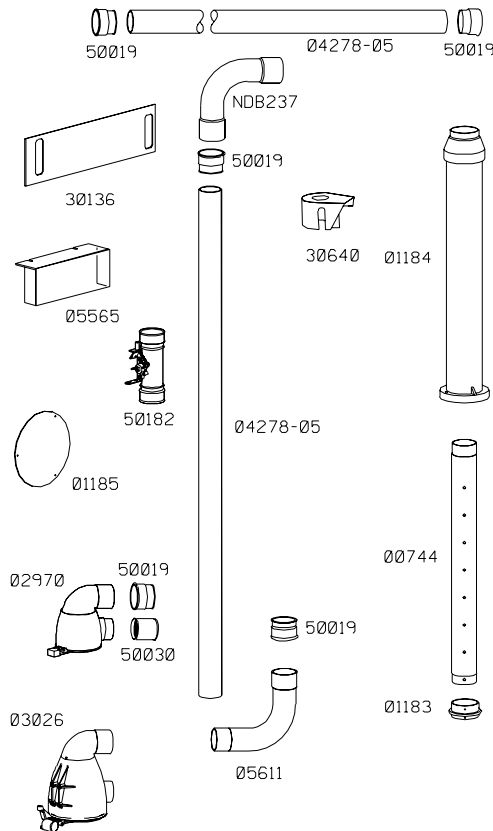

**Matec 4000 / Silver**

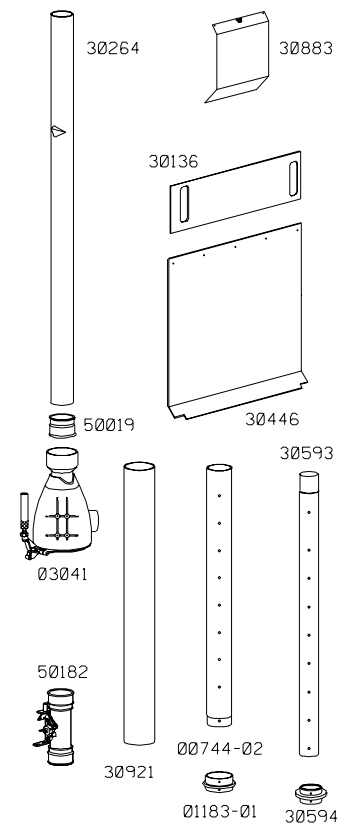

## Matec Sport ES

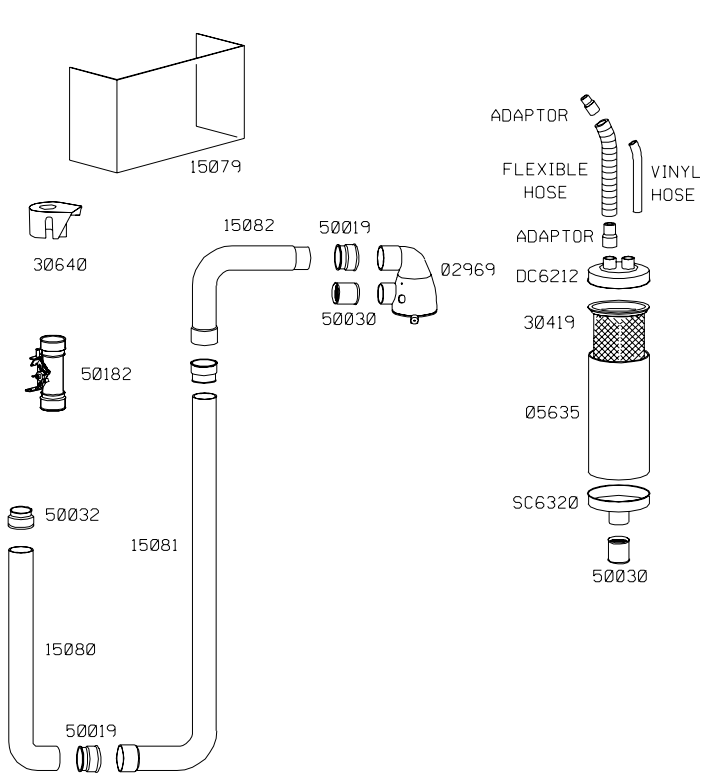

## Matec Ultra Sport

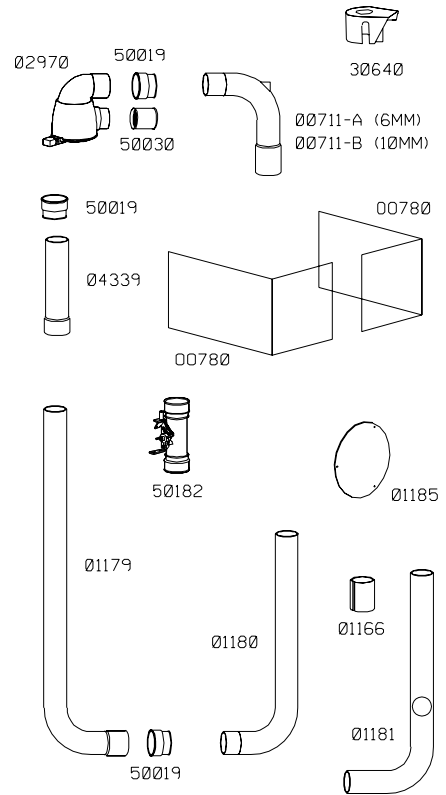

## Matec Sport GE

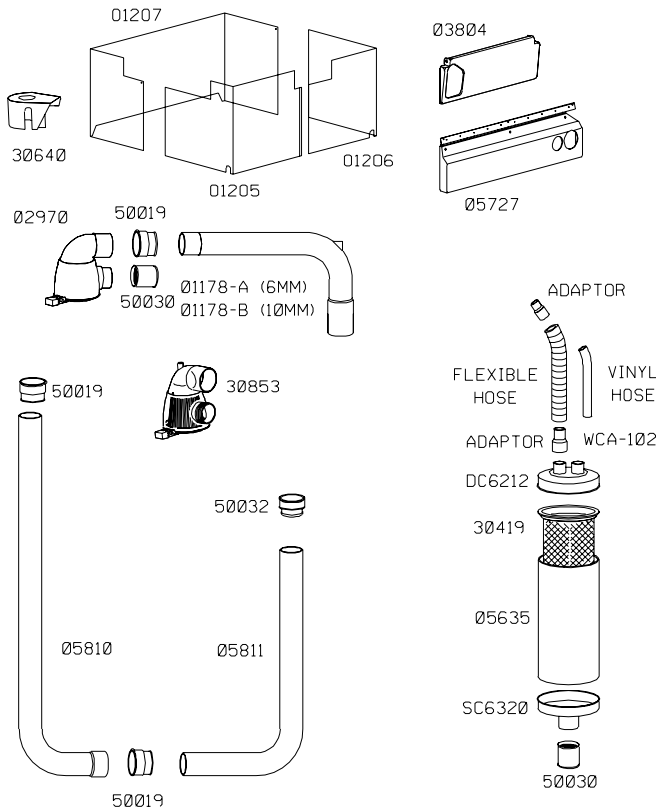

## Matec Sport DE

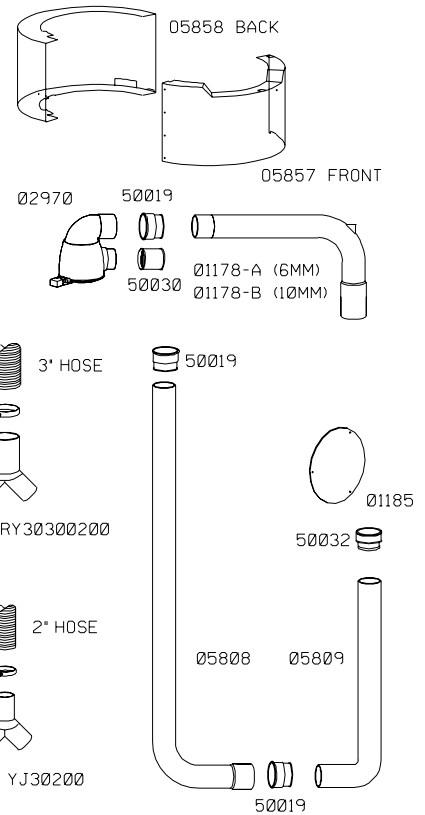



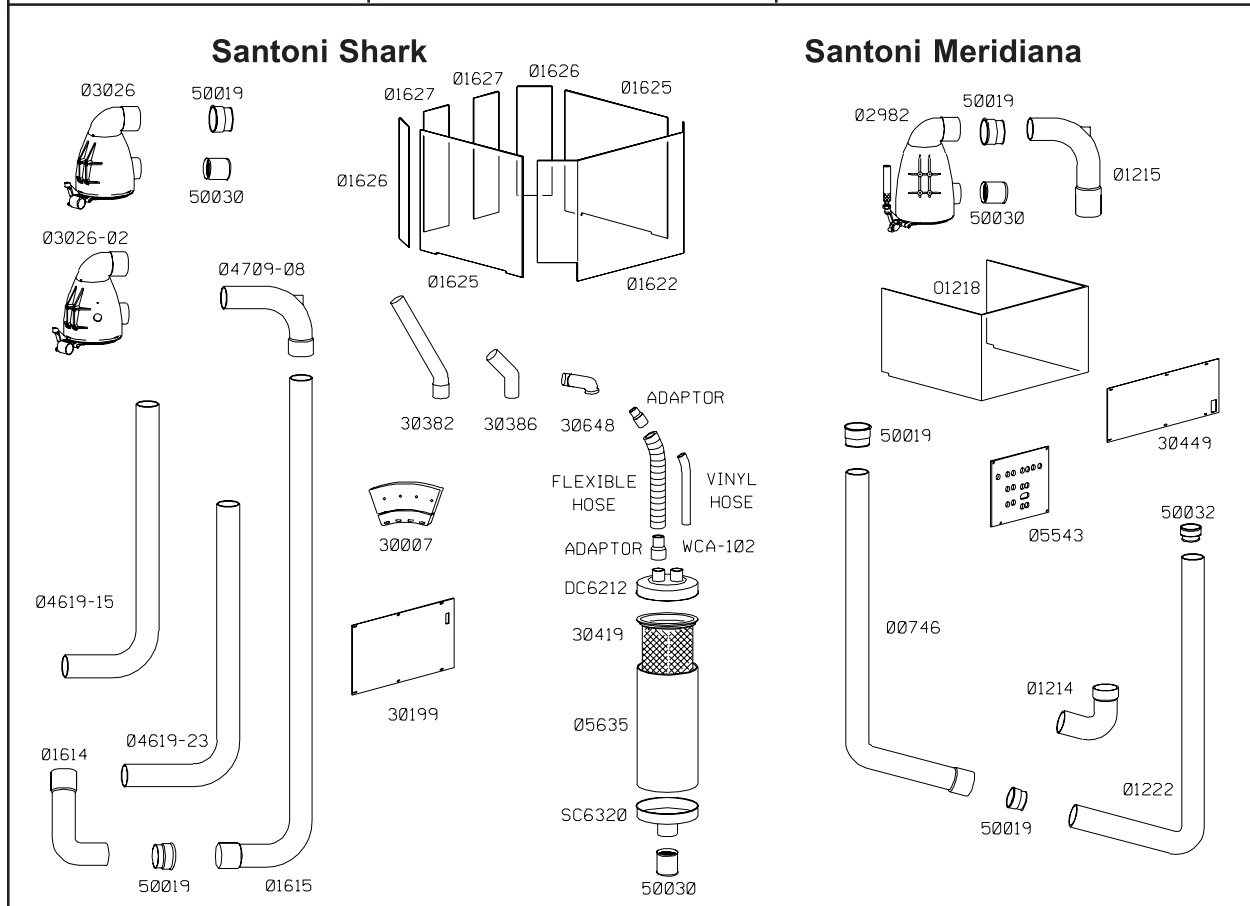
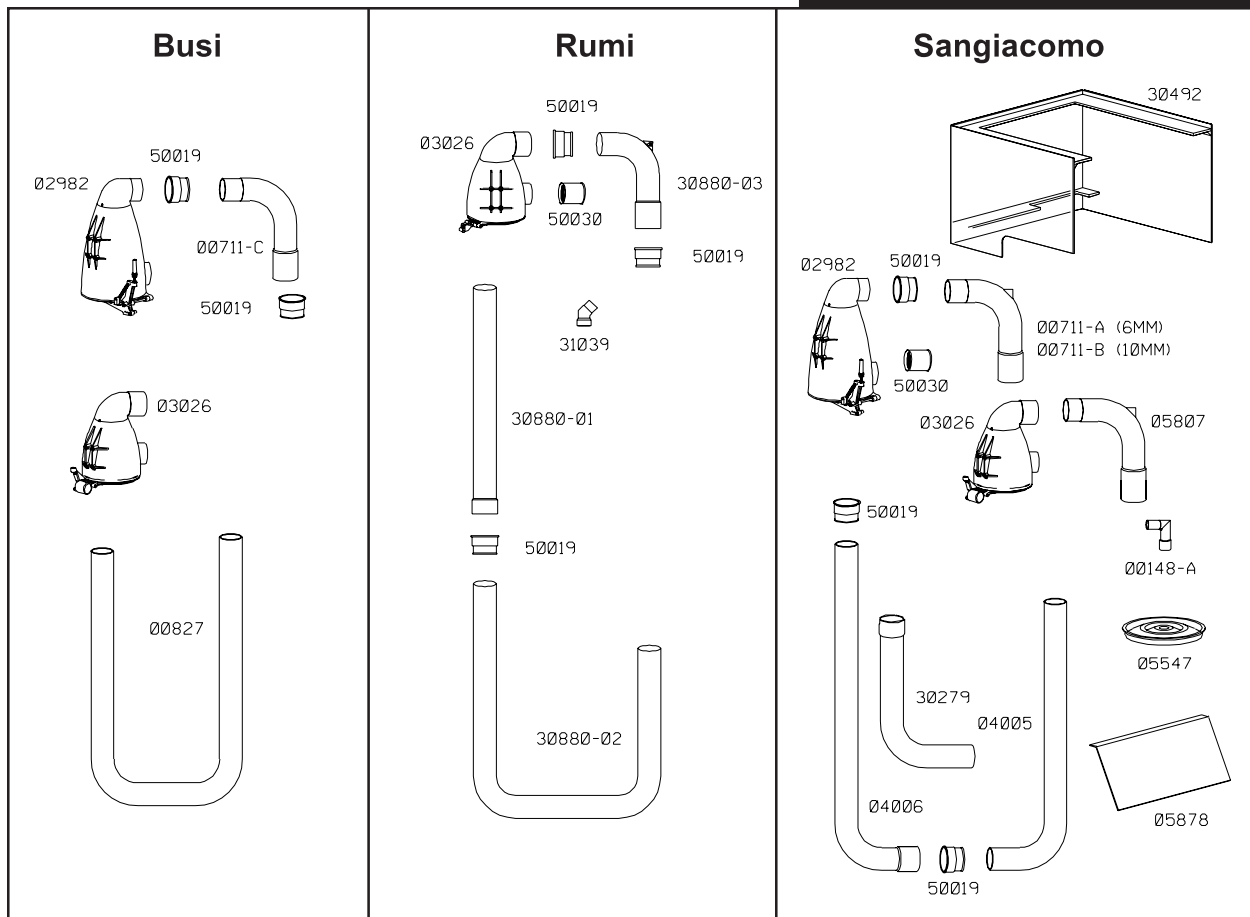

## Santoni Pendolina, Pendolina V

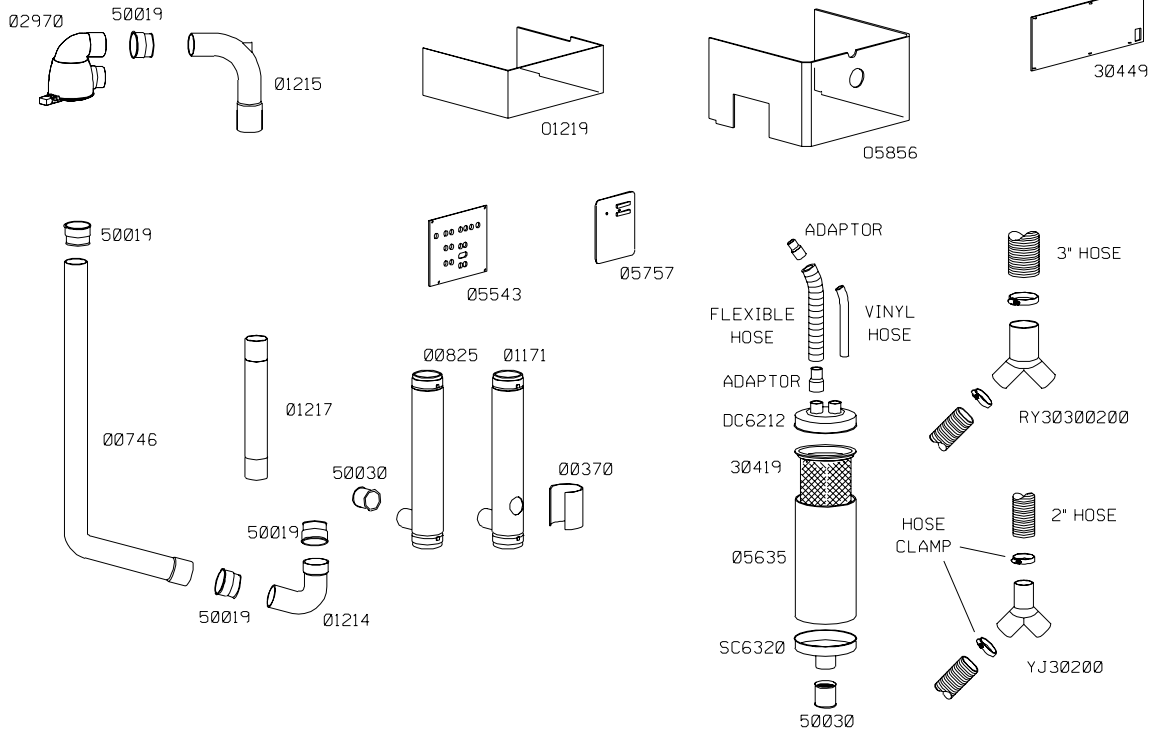

## Santoni Mirabella

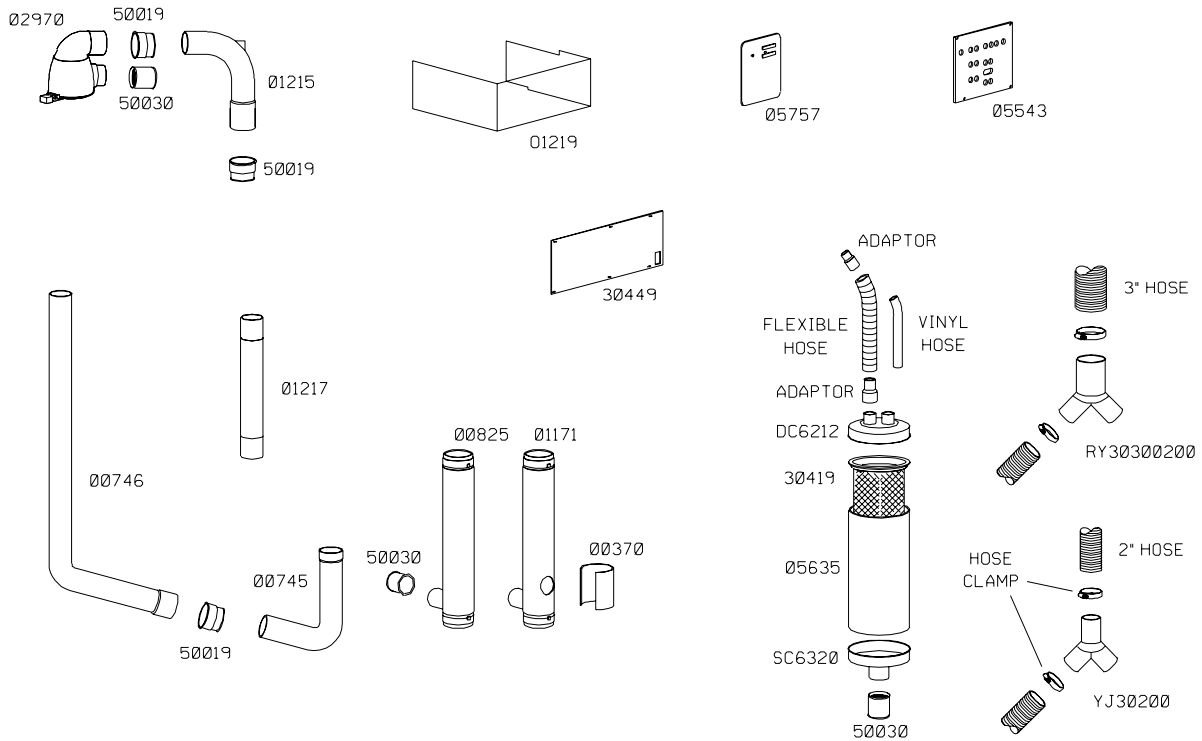

<p><b>Ange 4 &amp; 5</b></p>	<p><b>Ange 9</b></p>	<p><b>Uniplet Ange 11/12</b></p>	<p><b>Dera 3</b></p>	<p><b>Sabina</b></p>
<p><b>Fimatex</b></p>	<p><b>Solis-Hemphill</b></p>	<p><b>Crawford</b></p> <p>All Tubes Are Available</p>	<p><b>Bentley</b></p>	<p><b>Butterfly</b></p>
<p><b>Micro-Switch Holder</b></p> <p><b>Vacuum Valves</b></p>	<p><b>Product Diverter for 2"-2.5"OD Tubing</b></p> <p><b>5" Diverter</b></p>	<p><b>Cleaning Gun</b> Compressed Air Operated</p> <p><b>31165 Sock Funnel</b> 12 Open x 3" ID Bell</p>	<p><b>Inspection Forms</b></p>	<p><b>Pirn Liners</b> 5" &amp; 6" Diameter</p> <p><b>Yarn Disc</b></p>

# COLLECTOR UNITS

## 02970 SMALL COLLECTOR

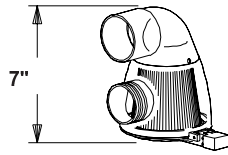

PART NO.	DESCRIPTION
02972	HOUSING
02973	ELBOW
02974	FILTER
02975	RING
02976	DOOR
02977	WEIGHT
02978	DOOR PIN
02979	WEIGHT PIN

## 03026 MEDIUM COLLECTOR

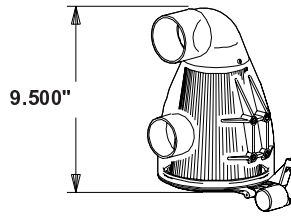

PART NO.	DESCRIPTION
03030	HOUSING
02973	ELBOW
03029	FILTER
03027	RING
03028	DOOR
03040	WEIGHT
03031	DOOR PIN

## LAYOUT UNIT

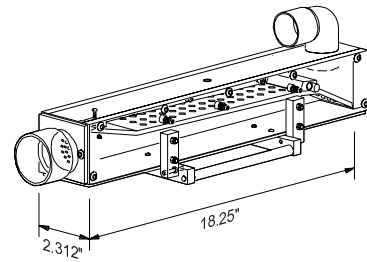

PART NO.	DESCRIPTION
30550	LARGE LAYOUT UNIT

## 02969 SMALL COLLECTOR WITH STOP MOTION HOLE

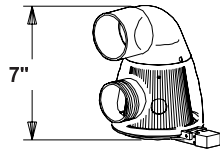

PART NO.	DESCRIPTION
02981	HOUSING
02973	ELBOW
02974	FILTER
02975	RING
02976	DOOR
02977	WEIGHT
02978	DOOR PIN
02979	WEIGHT PIN

## 03026-02 MEDIUM COLLECTOR WITH STOP MOTION HOLE

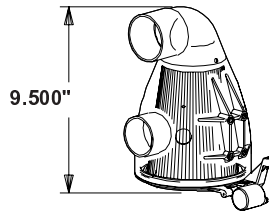

PART NO.	DESCRIPTION
03030-01	HOUSING
02973	ELBOW
03029	FILTER
03027	RING
03028	DOOR
03040	WEIGHT
03031	DOOR PIN

## 03041 MEDIUM COLLECTOR WITH TOP ENTRY

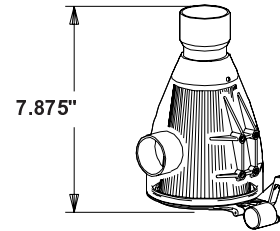

PART NO.	DESCRIPTION
03030	HOUSING
30445	INLET TUBE
03029	FILTER
03027	RING
03028	DOOR
03040	WEIGHT
03031	DOOR PIN

## Air Filter & Regulator

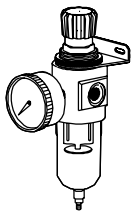

Filter & Regulator

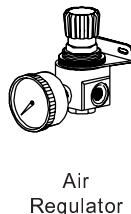

Air Regulator

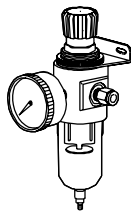

Filter & Regulator with Fittings

Part No.	Tube Dia.	Pipe Thread
AFR-150 Filter Regulator	-	1/8" NPT
AFR-200 Filter Regulator	-	1/4" NPT
AR-150 Air Regulator	-	1/8" NPT
25825 Filter Reg. w/ Fittings	1/4"	-
25833 Filter Reg. w/ Fittings	3/8"	-

## AIR GUN

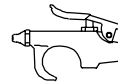

Metal Air Gun

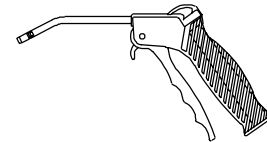

Plastic Air Gun

Part No.	Pipe Thread
AGM-1 Air Gun Metal	1/4"
AGP-1 Air Gun Plastic	1/4"

## IN-LINE WASTE CONTAINERS

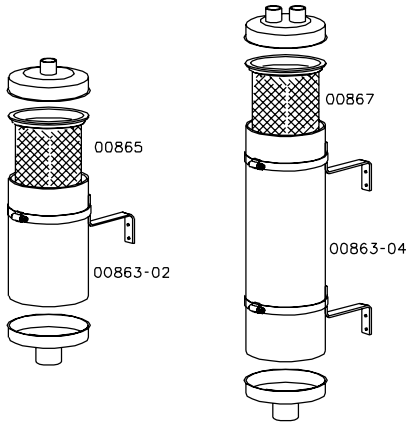

- DURABLE, CLEAR PLASTIC FOR EASY VISUAL INSPECTION OF WASTE LEVEL INSIDE FILTER
- REMOVABLE FILTER BASKET FOR QUICK AND EASY EMPTYING OF COLLECTED WASTE
- HIGH QUALITY FOR LONG LIFE - EVEN WHERE OIL IS PRESENT
- STEEL MOUNTING BRACKETS

Especially designed and built for the collection of yarn fibers, thread or small trim. Contaminated air enters through the top inlet cap into the filter where material is collected. The filtered air then travels through the bottom outlet cap to the vacuum system. When Ordering: Please Specify Cap Inlet Sizes.

CONTAINER DIAMETER	CONTAINER LENGTH	CAPACITY CUBIC INCHES	ASSEMBLY	ASSEMBLY & MOUNTING BRACKETS
6	12	186	IWC6012	IWC6012-MB
6	24	464	IWC6024	IWC6024-MB

## CANISTER CAPS

ENTRANCE OD	CANISTER SIZE DOUBLE INLET	
	5"	6"
5/8	DC5006	DC6006
1	DC5010	DC6010
1-1/4	DC5012	DC6012
1-1/2	DC5015	DC6015



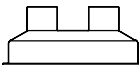

OD	SINGLE INLET	
	5"	6"
5/8	SC5006	SC6006
1	SC5010	SC6010
1-1/4	SC5012	SC6012
1-1/2	SC5015	SC6015
2	SC5020	SC6020
2-1/2	SC5025	SC6025
3	SC5030	SC6030

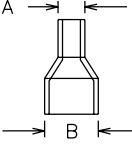

## HOSE / TUBE ADAPTERS

HOSE/TUBE SIZE (ID)	PART NUMBER		
	A	B	
7/8"	5/8 ID	7/8 OD	WCA-81
	7/8 OD	7/8 OD	WCA-82
	7/8 OD	1-1/4 OD	WCA-83
1"	5/8 ID	1 OD	WCA-84
	7/8 ID	1 OD	WCA-85
	1 OD	1 ID	WCA-101
	1 OD	1-1/4 ID	WCA-102
1-1/4"	1-1/4 ID	1-1/4 OD	WCA-122
	1-1/4 ID	1-1/4 OD	WCA-122
1-1/2"	1-1/2 OD	1-5/8 ID	RA162150



## SOUND ATTENUATORS / MUFFLERS

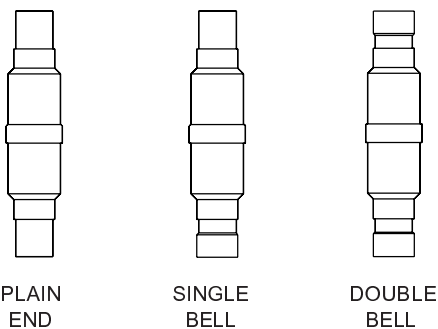

Reduces Sound Level. Designed for Material Handling Applications. Excellent for applications where compressed air intake or discharge sound levels are unacceptably high. Smooth bore allows goods or waste to transport through unit without a snag, but traps noise within.

A TUBE SIZE	REF. LENGTH	PART NUMBER		
		PLAIN END	SINGLE BELL	DOUBLE BELL
1	7-1/2	MPL100	MSB100	MDB100
1-1/2	7-1/2	MPL150	MSB150	MDB150
2	7-1/2	MPL200	MSB200	MDB200
2-1/4	16	MPL225	MSB225	MDB225
2-1/2	18	MPL250	MSB250	MDB250
3	18	MPL300	MSB300	MDB300
3-1/2	18	MPL350	MSB350	MDB350

## INLINE FILTERS

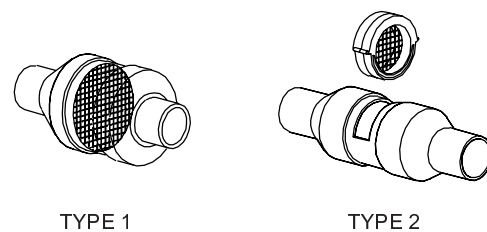

Designed for use with regenerative blowers & ring compressors. Prevents lint or dust particle build-up which may cause clogging and motor burn-out. Clear construction is ideal for visual control. Use Templex Reducer couplings or Reducing Adapters to adapt Standard Inline Filters to other tube or hose sizes.

Type 1 Filters Snap Apart to Clean Filter Media. Type 2 Filters Have a Removable Cartridge which Snaps Out for Cleaning.

FOR:	PART NUMBER	
TUBE SIZE OD	TYPE 1	TYPE 2
HOSE SIZE ID		
2	00734	05702
2-1/4	00652-03	05719
2-1/2	00652-01	05720
3	00652-02	----

# TUBING

## CLEAR VINYL TUBING

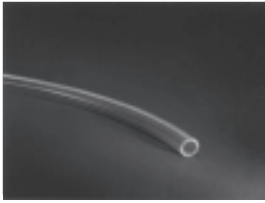

- LIGHTWEIGHT
- TOUGH
- TRANSPARENT
- NONTOXIC
- SMOOTH
- FLEXIBLE

STANDARD LENGTH - 100 FT.

PART NO.	I.D.	O.D.	WALL	PART NO.	I.D.	O.D.	WALL
VT-015	3/32	5/32	1/32	VT-14	3/8	5/8	1/8
VT-017	1/8	3/16	1/32	VT-18	1/2	5/8	1/16
VT-02	1/8	1/4	1/16	VT-19	1/2	11/16	1/16
VT-025	3/16	1/4	1/32	VT-20	1/2	3/4	1/8
VT-03	3/16	5/16	1/16	VT-22	9/16	3/4	3/32
VT-04	3/16	3/8	3/32	VT-25	5/8	13/16	3/32
VT-05	3/16	7/16	1/8	VT-26	5/8	7/8	1/8
VT-06	1/4	3/8	1/16	VT-31	3/4	1	1/8
VT-07	1/4	7/16	3/32	VT-32	3/4	1-1/16	5/32
VT-08	1/4	1/2	1/8	VT-33	7/8	1-1/8	1/8
VT-09	5/16	7/16	1/16	VT-35	1	1-1/4	1/8
VT-10	5/16	1/2	3/32	VT-37	1	1-3/8	3/16
VT-12	3/8	1/2	1/16	VT-39	1-1/4	1-1/2	3/32

## COMPRESSED AIR TUBING

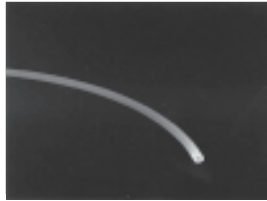

TUBING IS NATURAL COLOR EXCEPT AS NOTED.  
\* ONLY AVAILABLE IN BLACK.

PART NO.	TUBE OD	TUBE ID	MATERIAL
61118	3.0 MM	1.42 MM	NYLON
61560	4.0 MM	2.7 MM	NYLON
61960	5.0 MM	3.0 MM	NYLON
62320*	6.0 MM	4.0 MM	NYLON
62330*	6.0 MM	4.0 MM	POLYURETHANE
62340	8.0 MM	6.0 MM	NYLON
62350*	10.0 MM	7.5 MM	NYLON
61250	1/8"	.075"	NYLON
61330	3/16"	.137"	NYLON
62400	1/4"	1/8"	POLYETHELENE
62440	1/4"	.170"	POLYETHELENE
62500	5/16"	.232"	NYLON
62550	5/16"	3/16"	POLYETHELENE
62660	3/8"	1/4"	POLYETHELENE
62880	1/2"	3/8"	POLYETHELENE

## BRAIDED VINYL AIR HOSE

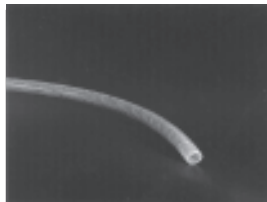

A GENERAL PURPOSE, LIGHTWEIGHT HOSE MADE OF CLEAR PVC REINFORCED WITH A POLYESTER CORD. USE THIS HOSE FOR : LUBRICATION LINES, VACUUM LINES, HYDRAULIC LINES, PNEUMATIC LINES, WATER FEEDS, GLUE LINES, & PACKAGING MACHINES.

PART NUMBER	I.D.	O.D.	MAXI. W.P. AT 70 DEGREES F.	STANDARD LENGTH
PBH 025	1/4	7/16	225 PSI	50, 100, & 300 FT
PBH 038	3/8	19/32	175 PSI	50, 100, & 300 FT
PBH 050	1/2	23/32	150 PSI	50, 100, & 300 FT
PBH 062	5/8	7/8	125 PSI	50, 100, & 300 FT
PBH 075	3/4	1-1/32	100 PSI	50, 100, & 300 FT
PBH 100	1	1-5/16	85 PSI	50, 100, & 300 FT

## DOUBLE - BRAIDED AIR HOSE



FOR USE WITH: AIR SYSTEMS, AIR OPERATED, TOOLS, WATER SYSTEMS, COOLANT LINES, & AIR ACTIVATING DEVICES

PART NUMBER	I.D.	O.D.	MAXI. W.P. AT 70 DEGREES F.	STANDARD LENGTH
PAH 025	1/4	1/2	250 PSI	50, 100, & 300 FT
PAH 038	3/8	5/8	250 PSI	50, 100, & 300 FT
PAH 050	1/2	13/16	250 PSI	50, 100, & 300 FT

## SELF LOCKING CABLE TIES

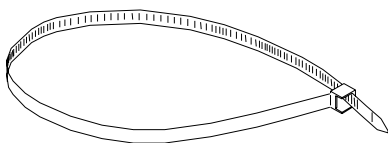

MAX. DIAMETER	LENGTH	PACKAGE QTY.	PART NUMBER
8-1/2	2	25	00572
14-1/4	4	25	00573

## #00570 TUBE CUTTER

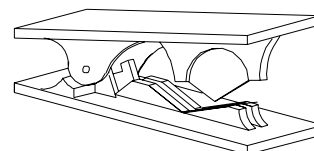

Razor sharp blade assures clean cuts on all types of plastic tubing

# VACUUM HOSE

## FLEX HOSE

PART NUMBER	HOSE (ID)	WEIGHT / FOOT	ROLL LENGTH	CASE QTY	USE HOSE CLAMP
FH750	3/4"	.10	50FT.	100FT.	00249-07
FH875	7/8"	.11	50FT.	250FT.	00249-09
FH100	1"	.12	50FT.	150FT.	00249-09
FH125	1-1/4"	.15	50FT.	200FT.	00249-10
FH150	1-1/2"	.17	50FT.	200FT.	00249-11
FH175	1-3/4"	.31	50FT.	200FT.	00249-12
FH200	2"	.33	50FT.	100FT.	00249-13
FH225	2-1/4"	.35	50FT.	100FT.	00249-14
FH250	2-1/2"	.42	50FT.	50FT.	00249-15
FH300	3"	.46	50FT.	50FT.	00249-17

- Reinforced with spring steel
- Smooth inner surface
- Flexible for tight radius bends

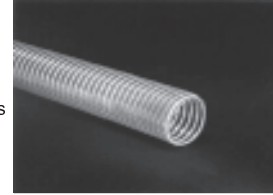

A high quality/low cost hose that is ideal for medium duty vacuum applications, such as discharge, dust collection and movement of light materials. Clear walls are ideal for visual control.

## HEAVY DUTY FLEX HOSE

PART NUMBER	HOSE (ID)	WEIGHT / FOOT	ROLL LENGTH	CASE QTY	USE HOSE CLAMP
SH-125	1-1/4"	.17	50FT.	200FT.	00249-10
SH-150	1-1/2"	.19	50FT.	200FT.	00249-11
SH-175	1-3/4"	.34	50FT.	100FT.	00249-12
SH-200	2"	.36	50FT.	100FT.	00249-13
SH-225	2-1/4"	.38	50FT.	100FT.	00249-14
SH-250	2-1/2"	.44	50FT.	50FT.	00249-15
SH-300	3"	.46	25FT.	25FT.	00249-17
SH-400	4"	.49	25FT.	25FT.	00249-21

- Reinforced with spring steel
- Smooth inner surface
- Flexible for tight radius bends

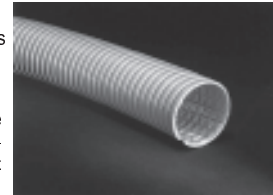

A high quality hose that is ideal for higher vacuum / discharge applications such as dust collection and movement of light materials. Gray color.

## POLY FLEX HOSE

- HIGHLY OIL RESISTANT
- LIGHTWEIGHT
- MOLDED RIB FOR REINFORCEMENT

PART NUMBER	HOSE (ID)	WEIGHT / FOOT	ROLL LENGTH	CASE QTY	USE HOSE CLAMP
PF870	7/8"	.003	50FT.	500FT.	00249-07
PF100	1"	.004	50FT.	500FT.	00249-09

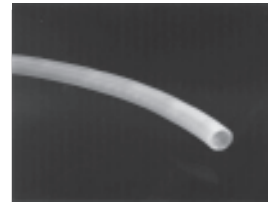

Stock lengths of 50, 100 and 500 feet.

## PLASTIC REINFORCED FLEXIBLE VACUUM HOSE

PART NUMBER	HOSE (ID)	WEIGHT / FOOT	ROLL LENGTH	USE HOSE CLAMP
PRH-100	1"	.21	100FT.	00249-10
PRH-125	1-1/4"	.28	100FT.	00249-11
PRH-150	1-1/2"	.23	100FT.	00249-12
PRH-173	1.730"	.44	100FT.	00249-13
PRH-200	2"	.30	100FT.	00249-14
PRH-220	2.200"	.62	100FT.	00249-15
PRH-250	2-1/2"	.39	100FT.	00249-16
PRH-300	3"	.50	100FT.	00249-18
PRH-350	3-1/2"	.62	100FT.	00249-21
PRH-400	4"	.77	100FT.	00249-22
PRH-500	5"	.91	100FT.	00249-25
PRH-600	6"	1.07	20FT.	00249-27
PRH-800	8"	1.74	20FT.	00249-28



REINFORCED WITH PLASTIC HELIX, MODERATELY FLEXIBLE WITH SMOOTH INNER SURFACE.

## HOSE CLAMPS

CLAMP RANGE	REF. NUMBER	PART NUMBER
7/32	5/8	HCM-4*
5/16	7/8	HCM-6*
9/16	1-1/4	HCM-12*
11/16	1-1/2	HCM-16*
7/8	1-3/4	HCM-20*
3/8	7/8	HC-6
7/16	1	HC-8
9/16	1-1/16	HC-10
9/16	1-1/4	HC-12
11/16	1-1/2	HC-16
3/4	1-3/4	HC-20
1-1/16	2	HC-24
1-5/16	2-1/4	HC-28
1-9/16	2-1/2	HC-32

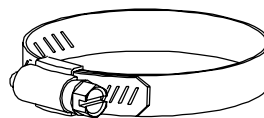

\*5/16 BAND WIDTH

CLAMP RANGE	REF. NUMBER	PART NUMBER
1-13/16	2-3/4	HC-36
2-1/16	3	HC-40
2-5/16	3-1/4	HC-44
2-9/16	3-1/2	HC-48
2-13/16	3-3/4	HC-52
3-1/16	4	HC-56
3-5/16	4-1/4	HC-60
3-9/16	4-1/2	HC-64
4-1/16	5	HC-72
4-5/8	5-1/2	HC-80
4-3/32	6	HC-88
4-1/2	6-1/2	HC-96
5	7	HC-104
5-3/4	7-3/4	HC-116

# AIR FITTINGS

Male Connector		Tube Dia.	Pipe Thread
	Part No.		
	50329	1/8"	10/32"
	ACM-25-01	1/4"	1/8"
	ACM-25-02	1/4"	1/4"
	ACM-38-01	3/8"	1/8"
	ACM-38-02	3/8"	1/4"
	50299	4mm	10/32"
	ACM-M04-01	4mm	1/8"
	01756	4mm	M 5
	ACM-M06-01	6mm	1/8"
	ACM-M06-02	6mm	1/4"
	ACM-M10-01	10mm	1/8"
	ACM-M10-02	10mm	1/4"

Female Connector		Tube Dia.	Pipe Thread
	Part No.		
	ACF-25-01	1/4"	1/8"
	ACF-25-02	1/4"	1/4"
	ACF-38-01	3/8"	1/8"
ACF-38-02	3/8"	1/4"	

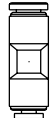
Reducing Connector		Tube Dia.	Tube Dia.
	Part No.		
	ACR-25M04	1/4"	4mm
	ACR-3825	3/8"	1/4"
	ACR-M06M04	6mm	4mm
ACR-M10M06	10mm	6mm	

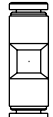
Union Connector		Tube Dia.	
	Part No.		
	ACU-25	1/4"	
	ACU-38	3/8"	
	ACU-M04	4mm	
	ACU-M06	6mm	
ACU-M10	10mm		

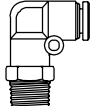
Male Elbow		Tube Dia.	Pipe Thread
	Part No.		
	AEM-25-01	1/4"	1/8"
	AEM-25-02	1/4"	1/4"
	AEM-38-01	3/8"	1/8"
	AEM-38-02	3/8"	1/4"
	AEM-M04-01	4mm	1/8"
	AEM-M06-01	6mm	1/8"
AEM-M06-02	6mm	1/4"	

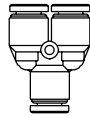
Union "Y"		Tube Dia.	
	Part No.		
	AYU-25	1/4"	
	AYU-38	3/8"	

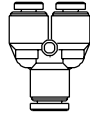
Reducing "Y"		Tube "M" Dia.	Tube "B" Dia.
	Part No.		
	AYR-25M04	1/4"	4mm
	AYR-3825	3/8"	5/16"
	AYR-M06M04	6mm	4mm
AYR-M10M06	10mm	6mm	

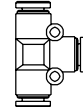
Union Tee		Tube Dia.	
	Part No.		
	ATU-25	1/4"	
	ATU-38	3/8"	
	ATU-M04	4mm	
ATU-M06	6mm		

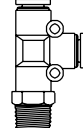
Male Street Tee		Tube Dia.	Pipe Thread
	Part No.		
	ATMS-25-01	1/4"	1/8"
	ATMS-25-02	1/4"	1/4"
	ATMS-38-01	3/8"	1/8"
	ATMS-38-02	3/8"	1/4"
ATMS-M04-01	4mm	1/8"	

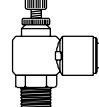
Flow Control		Tube Dia.	Pipe Thread
	Part No.		
	50395	1/4"	1/8"
		Air << Flow >>	

Plug for Auto Fittings		Tube Dia.	
	Part No.		
	APLG-25	1/4"	
	APLG-38	3/8"	
	APLG-M04	4mm	
	APLG-M06	6mm	
APLG-M10	10mm		

Male Connector- Barbed		Tube Dia.	Pipe Thread
	Part No.		
	00015	1/4"	10/32"
	00105	1/4"	1/8"
	00304	1/4"	1/4"
	00172	3/8"	1/8"
00526	3/8"	1/4"	

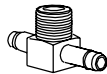
Male Branch Tee- Barbed		Tube Dia.	Pipe Thread
	Part No.		
	00564	1/4"	1/8"
	01968	1/4"	1/4"
	00565	3/8"	1/8"
00566	3/8"	1/4"	

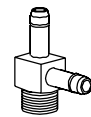
Male Run Tee- Barbed		Tube Dia.	Pipe Thread
	Part No.		
	50115	1/4"	1/8"
	50118	3/8"	1/8"

90 Degree Male Elbow- Barbed		Tube Dia.	Pipe Thread
	Part No.		
	00095	1/4"	1/8"
	00305	1/4"	1/4"
	00192	3/8"	1/8"
	00527	3/8"	1/4"

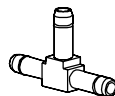
Union Tee- Barbed		Tube Dia.	Pipe Thread
	Part No.		
	00528	1/4"	1/4"
	00529	3/8"	1/4"
	00530	3/8"	3/8"



## COMPLETT

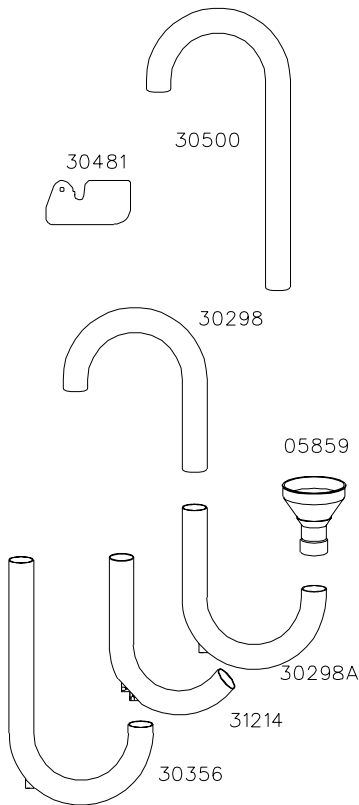

## DETEXOMAT

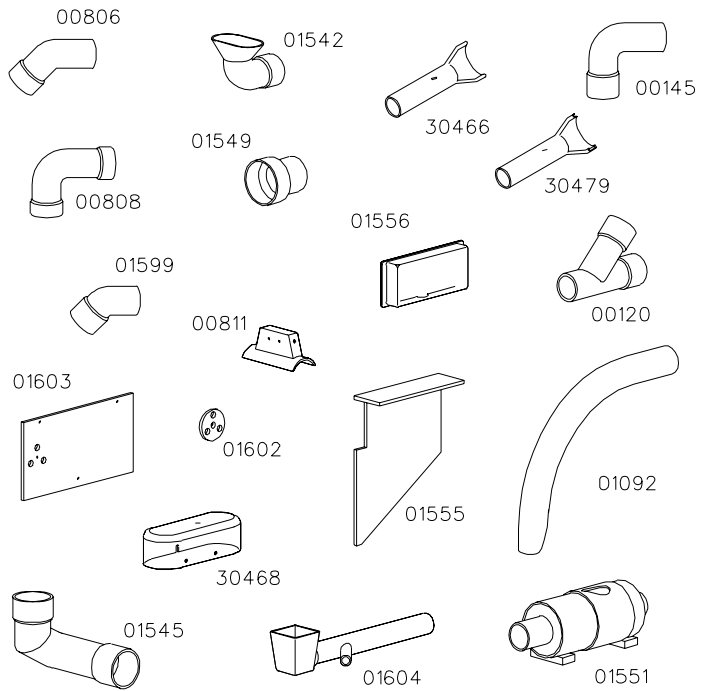

## ROSSO

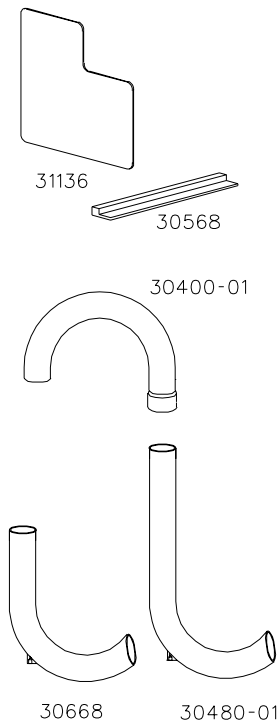

## TAKATORI

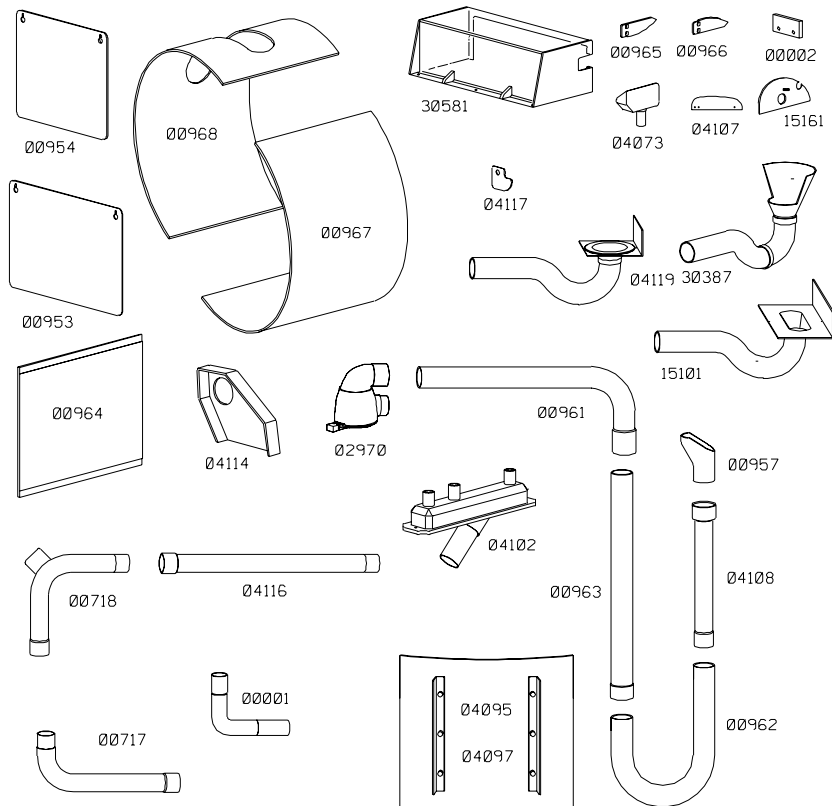

# SEAMING ACCESSORIES

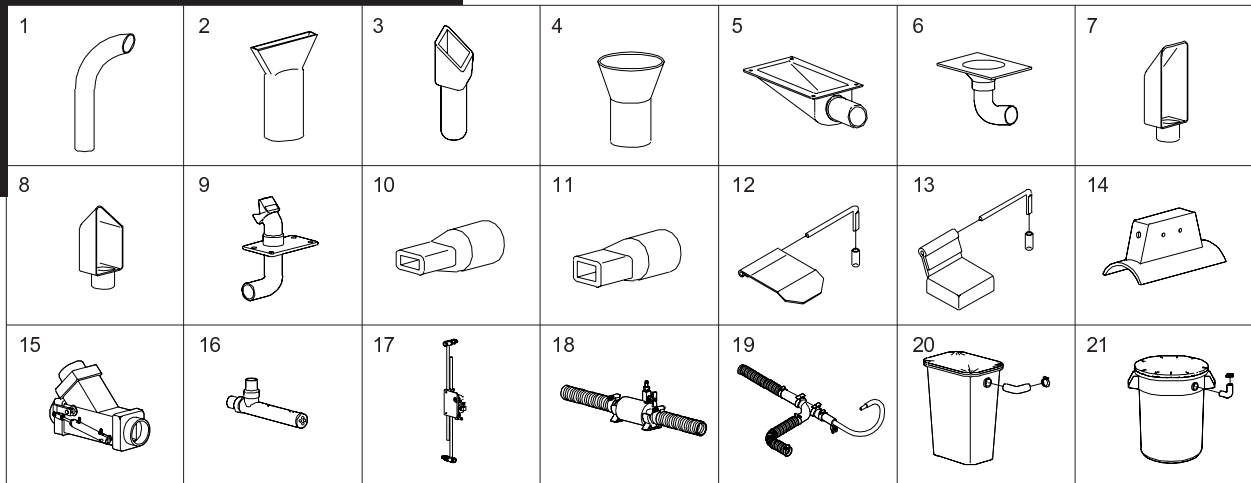

Item	Description	Part No.
1	1" OD Funnel 6" Tall	00161
	1-1/2" OD Funnel 6" Tall	02175
	2" OD Funnel 7" Tall	02306
2	1" OD Funnel 3/8" X 1-5/8" Open X 3" Tall	00814-01
	1-1/2" OD Funnel 1/2" X 2-5/8" Open X 5" Tall	00814-03
	2" OD Funnel 1/2" X 3-1/2" Open X 6" Tall	00814-04
3	1" OD Funnel 1" X 1" Open X 5" Tall	02307
	1-1/2" OD Funnel 1-5/8" X 1-5/8" Open X 6-1/4" Tall	00815-03
	2" OD Funnel 2-1/8" X 2-1/8" Open X 6-1/4" Tall"	00815-04
4	1" OD Funnel 1-5/8" Diameter Open X 2-1/2" Tall	02308
	1-1/2" OD Funnel 2-1/2" Diameter Open X 3" Tall	00252
	2" OD Funnel 2-3/4" Diameter Open X 3" Tall	00251
5	1" OD Funnel 2-3/4" X 4-5/8" Open, 3/4" Lip, 2-1/4" Tall	00713-01
	1-1/4" OD Fnl. 2-3/4" X 4-5/8" Open, 3/4" Lip, 2-1/4" Tall	00713-02
	1-1/2" OD Fnl. 2-3/4" X 4-5/8" Open, 3/4" Lip, 2-1/4" Tall	00713-03
	2" OD Funnel 2-3/4" X 4-5/8" Open, 3/4" Lip, 2-1/4" Tall	00713-05
6	1" OD Funnel 2-1/2" Open, 3-3/4" X 5"	04032
	1-1/4" OD Funnel 2-1/4" Open, 3-3/4" X 5"	00625
	1-1/2" OD Funnel 2-1/2" Open, 3-3/4" X 5"	03999
7	1-1/2" OD Funnel 2-1/4" X 5-1/2" Open X 7" Tall	00816-01
	2" OD Funnel 2-1/4" X 5-1/2" Open X 7" Tall	00816-02
8	1-1/2" OD Funnel 2-1/4" X 5-1/2" Open X 7" Tall	00817-01
	2" OD Funnel 2-1/4" X 5-1/2" Open X 7" Tall	00817-02
9	1-1/2" OD Funnel Assembly Union Special 39500	TBV-000-307
	1-1/2" OD Funnel Assembly Merrow M/MG	TBV-000-312

Item	Description	Part No.
10	Burner Adapter 1/4" ID X 1/2" X 1/2" OD Round	00818-05
	Burner Adapter 1/4" ID X 1/2" X 5/8" OD Round	00818-04
	Burner Adapter 1/4" ID X 1/2" X 7/8" OD Round	00818-03
	Burner Adapter 1/4" ID X 1/2" X 3/4" OD Round	00818-02
	Burner Adapter 1/4" ID X 1/2" X 1" OD Round	00818-01
11	Burner Adapter 3/8" ID X 1/2" X 1/2" OD Round	04078-01
	Burner Adapter 3/8" ID X 1/2" X 5/8" OD Round	04078-02
	Burner Adapter 3/8" ID X 1/2" X 3/4" OD Round	04078-03
	Burner Adapter 3/8" ID X 1/2" X 7/8" OD Round	04078-04
	Burner Adapter 3/8" ID X 1/2" X 1" OD Round	04078-05
12	Needle Guard Eye Shield Assembly FLAT Type	03952
13	Needle Guard Eye Shield Assembly BOX Type	04002
14	Micro Switch Holder Fits 2-1/2" - 3" OD Tubing	00811
15	Goods Diverter For 2" OD Tube	04083
	Goods Diverter For 2-1/4" OD Tube	05812
	Goods Diverter For 2-3/8" OD Tube	04034
16	Goods Diverter For 2-1/2" OD Tube	05766
	Vacuum Diverter (Air Only) 2" OD	00801
17	Treadle Switch, Toe Action	TBV-100LT
17	Treadle Switch, Heel Action	TBV-105
	Treadle Switch, 3-Position	TBV-110LT
18	1-1/2" Waste Removal Assembly	TBV-125
19	1-1/2" Chain & Waste Removal Assembly	TBV-400
20	1-1/2" Waste Canister, 10-1/4 Gallon Capacity	TBV-145
21	1-1/2" Waste Canister, 20 Gallon Capacity	TBV-166

## Sewing Waste Removal Systems

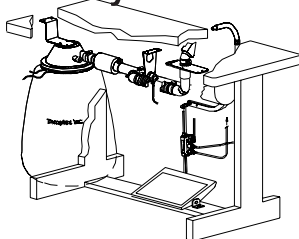

Patented systems are designed for use with sewing machines having chain cutters or burners. Effectively provides vacuum for removing chain and/or trimmed waste from sewing machine. The specialized design style funnel locates up around trimming knives and captures the lint as well as the waste. Used with treadle rod air switch and waste bag unit.

## #03238 Turning Unit

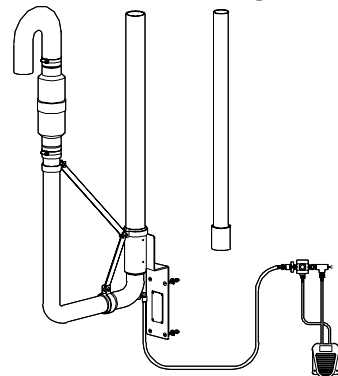

This compressed air operated unit is ideal for turning and inspecting socks. Assembly comes with a foot pedal, 2" OD & 2-1/2" OD Turning Tubes, and all necessary hardware for easy operation and installation.

Templex offers a variety of turn-sew-turn units. Please select the unit with the vacuum source, activation method, and mounting base which best suit your needs.

**Vacuum Source:** Vacuum for turning can be created by **compressed air** from a compressed air system or from an external source such as a central **vacuum** system or an individual vacuum unit to turn goods. Both types are ideal for turning socks or stockings.

**Activation Method:** Turn-sew-turn units are activated by a foot pedal, a heel operated treadle switch, or a 3-position treadle switch. The **foot pedal** operates independently of the sewing machine and activates vacuum when pressed. The **heel operated treadle switch** installs between the motor clutch lever and treadle and activates vacuum when the treadle is heeled. The **3-position treadle air switch** activates vacuum when heeling and activates a compressed air operated chain and waste removal system when toeing the treadle.

**Mounting Base:** Two types of mounting bases are available: Fixed Base and Swivel Base. The Fixed Base holds the turning tube stationary in a fixed position. The Swivel Base allows the turning tube to be raised or lowered and pivot in and out for loading and sewing.

All turn-sew-turn units come complete with 2" and 2-1/2" diameter turning tubes, necessary mounting hardware, and the compressed air tube and fitting needed to complete the installation.

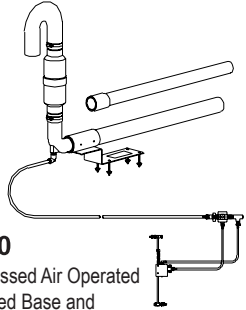
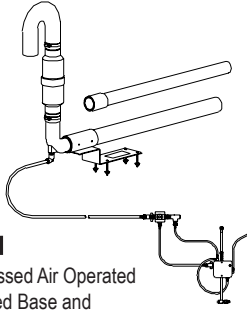
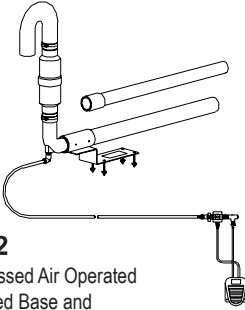
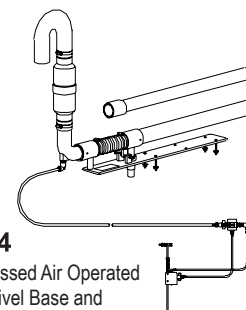
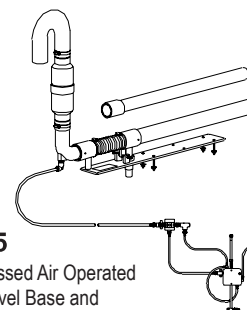
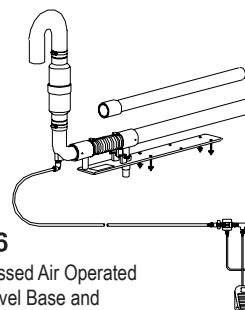
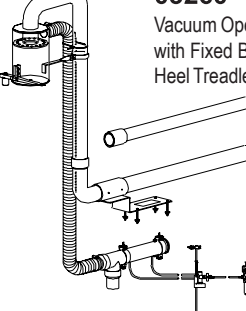
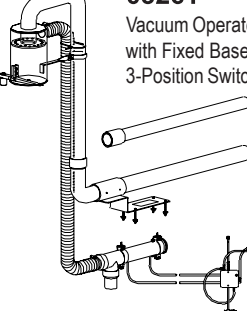
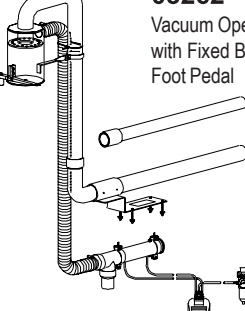
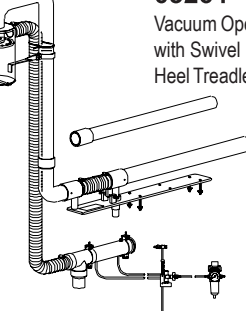
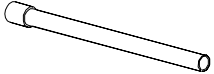
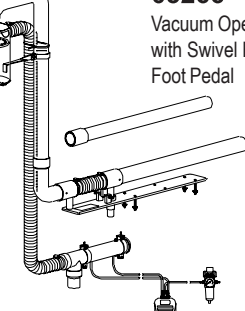
 <p><b>03250</b> Compressed Air Operated with Fixed Base and Heel Treadle Switch</p>	 <p><b>03251</b> Compressed Air Operated with Fixed Base and 3-Position Treadle Switch</p>	 <p><b>03252</b> Compressed Air Operated with Fixed Base and Foot Pedal</p>																											
 <p><b>03254</b> Compressed Air Operated with Swivel Base and Heel Treadle Switch</p>	 <p><b>03255</b> Compressed Air Operated with Swivel Base and 3-Position Treadle Switch</p>	 <p><b>03256</b> Compressed Air Operated with Swivel Base and Foot Pedal</p>																											
 <p><b>03260</b> Vacuum Operated with Fixed Base and Heel Treadle Switch</p>	 <p><b>03261</b> Vacuum Operated with Fixed Base and 3-Position Switch</p>	 <p><b>03262</b> Vacuum Operated with Fixed Base and Foot Pedal</p>																											
 <p><b>03264</b> Vacuum Operated with Swivel Base and Heel Treadle Switch</p>	<p><b>PLASTIC TURNING TUBES</b></p>  <table border="1"> <thead> <tr> <th>TUBE OD</th> <th>32" LONG</th> <th>36" LONG</th> </tr> </thead> <tbody> <tr> <td>1</td> <td>01116-01</td> <td>01235-01</td> </tr> <tr> <td>1-1/4</td> <td>01116-02</td> <td>01235-02</td> </tr> <tr> <td>1-1/2</td> <td>01116-03</td> <td>01235-03</td> </tr> <tr> <td>1-3/4</td> <td>01116-04</td> <td>01235-04</td> </tr> <tr> <td>2</td> <td>01116-05</td> <td>01235-05</td> </tr> <tr> <td>2-1/4</td> <td>01116-06</td> <td>01235-06</td> </tr> <tr> <td>2-3/8</td> <td>01116-07</td> <td>01235-07</td> </tr> <tr> <td>2-1/2</td> <td>01116-08</td> <td>01235-08</td> </tr> </tbody> </table>	TUBE OD	32" LONG	36" LONG	1	01116-01	01235-01	1-1/4	01116-02	01235-02	1-1/2	01116-03	01235-03	1-3/4	01116-04	01235-04	2	01116-05	01235-05	2-1/4	01116-06	01235-06	2-3/8	01116-07	01235-07	2-1/2	01116-08	01235-08	 <p><b>03266</b> Vacuum Operated with Swivel Base and Foot Pedal</p>
TUBE OD	32" LONG	36" LONG																											
1	01116-01	01235-01																											
1-1/4	01116-02	01235-02																											
1-1/2	01116-03	01235-03																											
1-3/4	01116-04	01235-04																											
2	01116-05	01235-05																											
2-1/4	01116-06	01235-06																											
2-3/8	01116-07	01235-07																											
2-1/2	01116-08	01235-08																											

Distributed By:

***Templex inc.***

**Shipping:**  
Templex Inc.  
3 Stanley Ave.  
Thomasville, NC 27360 USA

**Mailing:**  
Templex Inc.  
PO Box 5648  
High Point, NC 27262 USA

Telephone ..... 336-472-5933  
Fax ..... 336-472-5944  
Toll Free USA ..... 1-800-344-2725  
E-Mail ..... [Sales@TemplexInc.com](mailto:Sales@TemplexInc.com)  
Web ..... [www.TemplexInc.com](http://www.TemplexInc.com)

Products for Hosiery Manufacturing Equipment