

## COMPRESSED AIR CONSUMPTION FOR TEMPLEX WASTE REMOVAL SYSTEMS

### GENERAL INFORMATION

CFM = Cubic feet per minute  
 LPS = Liters per second  
 LPM = Liters per minute (LPS x 60 = LPM)  
 1 CFM = 28.3 LPM (.47195 LPS x 60 = 28.3 LPM)  
 PSI = Air Pressure- Pounds per square inch  
 1 PSI = .06895 Bar,  
 Example: 80 PSI = (.06895 x 80) = 5.5 Bar

### TYPICAL AIR COMPRESSOR CAPACITY

**Piston Type:** Each 1 HP Generates approximately **3 SCFM** or **84.9 LPM**  
**Screw Type:** Each 1 HP Generates approximately **4 SCFM** or **113.2 LPM**

Example: A 25 HP. Screw Type air compressor will produce 100 SCFM or 2830 LPM (liters per minute) (25hp x 4 SCFM) = 100 SCFM or (25 HP x 28.3 lpm) = 2830 LPM.

The air consumption for chain removal only will be the same for a Templex Dual Chain & Waste Removal System. Always use a Templex Patented Dual Chain & Waste Removal Vacuum Assembly when vacuum is needed for both a chain cutter and trimmed waste removal to conserve compressed air. The Templex chain removal vacuum and the dual chain and waste removal vacuums **operate best at 80 psi or 5.5 bar. Compressed air consumption will vary from machine to machine depending on air pressure, flow control adjustment, weight of fabric, thread, and actual sewing cycle.**

**EXAMPLE 1:** 40 overlock/safety stitch machines sewing a light weight to medium weight knit or woven fabric using T-150 texturized poly or 100s/2 cord spun polyester thread.

AIR PRESSURE: 80 psi or 5.5 bar.  
 SEWING CYCLE: 50% to 60%  
 FLOW CONTROL ADJUSTMENT: opened counter clockwise one mark on Treadle Rod Air Switch.  
 CFM used Per Machine (approximate) = 2 to 2.5 cfm. **CFM total: 2.5 cfm x 40 machines = 100 scfm**

Compressor Recommendation: Minimum of **25 HP Screw Type (100 Total cfm ÷ 4 = 25 HP)** or minimum of 35 HP Piston Type (**100 Total cfm ÷ 3 = 35 HP**). Consider next compressor size up to allow for future needs.

**EXAMPLE 2:** 30 overlock / safety stitch machines sewing a heavy denim fabric using a 40s/3 cord cotton thread.

AIR PRESSURE: 80 psi or 5.5 bar  
 SEWING CYCLE: 70%  
 FLOW CONTROL ADJUSTMENT: opened counter clockwise two marks on Treadle Rod Air Switch.  
 CFM used Per Machine (approximate) = 3.5 to 4 cfm. **CFM total: 4 cfm x 30 machines = 120 scfm**

Compressor Recommendation: Minimum of **30 HP Screw Type (120 Total cfm ÷ 4 = 30 HP)** or minimum of 40 HP Piston Type (**120 Total cfm ÷ 3 = 40 HP**). Consider next compressor size up to allow for future needs.

**IMPORTANT!!** These are estimates and may vary depending on proper installation and size of main air supply trunk line, altitude, proper installation of Templex waste removal products, and percentage of pressure drop when vacuum is activated

## COMPRESSED AIR CONNECTION DIAGRAM

Proper pneumatic connections using 24 volt DC solenoid valves.

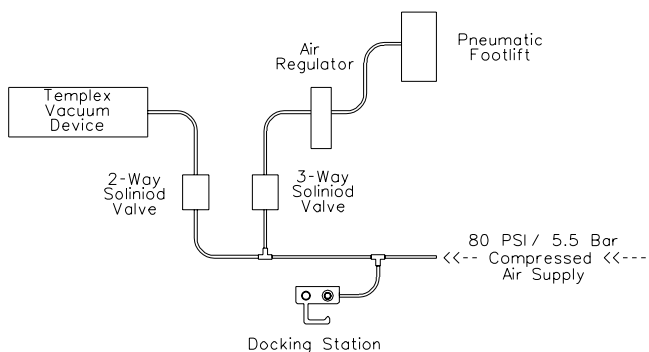

Note: A 3-way solenoid is necessary to operate a single acting air cylinder

Proper pneumatic connections using a Templex Lite Touch Treadle Rod Air Switch.

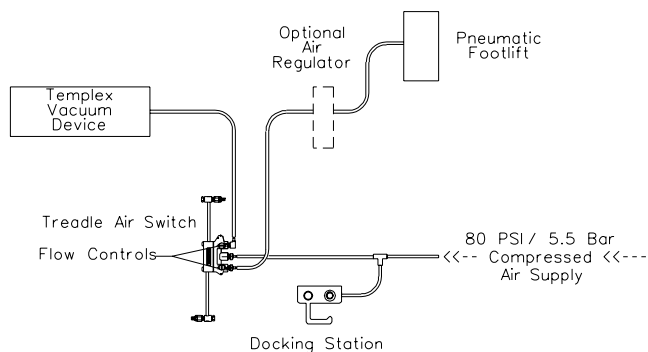

Note: Use of a filter regulator is not necessary when using a Templex Lite Touch Treadle Rod Air Switch with built in flow controls